



**GREAT NORTHERN**  
METAL COMPANY

**EXPOSED FASTENER PLYWOOD  
INSTALLATION DETAILS**

PANEL INFO (AS APPLICABLE)

- a. UL 90 — Uplift Rating
- b. UL-580 / 1897 — Uplift Test
- c. UL 2218 — Hail Resistance
- d. UL Class A Fire Rating



Tuf Rib Panel



PBR Panel



Rugged Rib Panel



Lo Pro Panel



7.2 Box Rib Panel



7/8" Corrugated Panel



1/4" Corrugated Panel



1/2" Corrugated Panel



# GNMC

## TABLE OF CONTENTS

Introduction	1
Safety, Material Storage	2
Cleaning and Maintenance Guide	3
Tuf Rib & Rugged Rib Fastener Layout	5
PBR & Lo Pro Panel Fastener Layout	6
7/8" Corrugated Fastener Layout	7
1/2" Corrugated Fastener Layout	8
1/4" Corrugated & 7.2 Box Rib Panel Fastener Layout	9
E1 – 4" Eave Detail	10
E2 – 6" Eave Detail	11
SD1 – Style D Detail	12
G1 – 4" Gable / Rake Detail	15
G2 – 6" Gable / Rake Detail	16
PG1- Prow Gable Detail	17
V1 – Valley Detail	18
EW1 – Endwall Detail	19
EW2 – Endwall Detail	20
SW1 – Sidewall Detail	21
SW2 – Sidewall Detail	22
HR1 – Hip Ridge Detail	23
VR1 – Vented Ridge Detail	24
NVR1 – Non-Vented Ridge Detail	25
TC1 – 4" Top Cap Detail	26
TC2 – 6" Top Cap Detail	27
T1 – Roof Transition Detail	28
B1 – Base Flashing Detail	29
BB1- Broom Base Flashing Detail	30
WC1- Wainscot Flashing Detail	31
JC1 – J-Channel Detail	32
OSC – Outside Corner Detail	33
ISC – Inside Corner Detail	34
PB1 – Pipe Boot	33



# GNMC

## INTRODUCTION

The application and detail drawings in this guide are strictly for illustration purposes only and may not be applicable to all building designs. It is the responsibility of the designer, roofing contractor and installer to ensure that the following details are adapted to meet the individual building requirements.

Great Northern Metal Company is held harmless from all claims resulting from a lack of water tightness as a result of following these suggested typical detail drawings.

The installer shall be familiar with all construction instructions and examine the roof substrate to ensure it meets the minimum requirements and that the building is square before starting any work. Report any potential problems to the general contractor or architect. Work should not start until all unfavorable conditions have been corrected.

When starting panel installation ensure panels are held true, plumb and straight. This can be done with the 3,4,5 method. Measure 3' across the eave and 4' up the plane of the roof, the diagonal line between the two will be 5'. All panel widths are nominal and it is recommended that periodic measurements be taken to ensure panels are not gaining or losing width.

Oil Canning can be described as the amount of waviness found in the flat area of metal panels. Oil canning is an inherent characteristic of light gauge cold formed metal products and is not a cause for rejection.

Sealant for joints and flashing conditions shall be non-drying, non-toxic, non-shrinking and shall have a serviceable temperature range of -50°F to 212°F. Sealant shall be field applied on clean, dry surfaces without any skips or voids in the bead. Sealant shall be supplied or approved by Great Northern Metal Company.

Tin snips or a “nibbler” type electric tool or high tooth carbide circular saws are recommended for field cutting panels, torches and plasma cutters are not to be used. All metal filings must be removed to avoid rusting the metal surfaces which could void the paint warranty and shorten the life of the product.

When working dissimilar metals or PT wood a separation barrier must be used to prevent contact between metals and PT wood. Stainless-steel fasteners should only be used when fastening into PT wood.

It is the building's owner or design professionals' responsibility to consult with the controlling code agency officials or other governing authorities to determine the specific requirements of each project and system.

Great Northern Technical Dept. should be contacted at 406-624-0435 when local codes or insurance requirements conflict with Great Northern recommendations. When shop drawings are approved by Great Northern Technical Department, they will supersede over any and all other drawings.



# GNMC

## SAFETY

It is the installer's responsibility to study all applicable OSHA and other safety requirements before starting any projects.

Safety railing, netting, harnesses, and safety lines should be provided and used by all crew members working on the roof.

All personal protective equipment (i.e., long pants, long sleeves, gloves, hard hat, safety glasses) should be worn when installing or handling products. Soft soled boots or shoes are recommended.

## MATERIAL STORAGE

Unload material and inspect for damage. Notify your sales contact immediately for any damaged material.

It is recommended by the NCCA that pre-painted material be stored in an indoor facility isolated from the elements. If material must be stored outside proper precautions must be taken.

If the bundles are to be stored on the ground, a plastic cover must be put down under the bundle to minimize condensation of water from the ground onto the panels. All bundles must be then raised off the ground cover to avoid contact with puddles and allow for air circulation around the bundles to promote drying of condensed water. The panels must be stored at an angle to promote drainage of water off the bundle. Sufficient support must be used to the raised and angled bundles to avoid bowing, which may result in low spots that could pool moisture.

The bundle must be completely covered with a loose-fitting waterproof tarp to protect the bundle during rain or snow events but allow for air circulation and drying of condensed water.

In addition to water there are other important factors that contribute to the corrosion of stored, pre-painted panels. These factors are temperature and exposure time. Given enough time, panels will eventually become wet and storage corrosion may occur under most job site conditions. Even in a well-protected bundle the natural temperature and humidity variations will cause water to condense on and between the panels. Shipping the bundle from a cold area to a warm area will cause water to condense not only on the bundle but also between the panels.

In conclusion, storage corrosion can be prevented by:

1. Decreasing water contact.
2. Moderating temperature extremes.
3. Immediately drying moisture exposed bundles.
4. Reducing site storage time.
5. Strippable plastic should be removed within 90 days.



# GNMC

## **CLEANING AND MAINTENANCE GUIDE**

### **for PVDF or SMP paint finishes**

PVDF finished such as Kynar 500 or Hylar 5000 resin paint systems are similar in structure to Teflon. Their slick surface helps make them resistant to many elements found in the environment such as air pollution, acid rain and general airborne dirt.

Although factory applied finishes are extremely durable, a periodic cleaning to remove buildups of resins and other residue is a good idea to extend coating life. A variety of methods for removal of surface deposits are available. Simple washing with plain water using hoses or pressure spray equipment is usually adequate. When surfaces are dulled with heavy deposits of dirt or other contaminants, stronger methods may be needed.

Two precautions: (1) do not use wire brushes, abrasives or similar cleaning tools which will mechanically abrade the coatings surface and (2) certain cleaning agents listed below should be tested in an inconspicuous area before use on a large scale.

### **HOT OR COLD DETERGENT SOLUTIONS**

A 5% solution in water of commonly used commercial and industrial detergents will not have any deleterious effect on a fluoropolymer surface. These solutions should be followed by an adequate rinse of water. Use a cloth or sponge for application.

### **SOLVENTS**

Most organic solvents are flammable and/or toxic and must be handled accordingly. Keep away from open flames, sparks and electrical motors. Use adequate ventilation, protective clothing and goggles.

Solvents that may be used to remove non-water soluble deposits (tar, grease, oil, paint, graffiti, etc.) from fluoropolymer surfaces include:



# GNMC

## Alcohols

- Denatured alcohol (ethanol)
- Isopropyl (rubbing alcohol)
- Methanol (wood

alcohol) Note: methanol is

toxic.

The above alcohols have no permanent effect on fluoropolymer surfaces.

**Mildew:** In areas subject to high humidity levels- dirt and spore deposits can permit mildew growth to occur. The following solution is recommended to remove mildew when necessary:

- 1/3 cup dry powdered laundry detergent (such as Tide®)
- 1 quart sodium hypochlorite 5% solution (such as Clorox®)
- 3 quarts water

**Rust Stains:** Hydrochloric, citric acid or muriatic acid, diluter with ten volumes of water, may assist in removing rust stain from fluoropolymer surfaces. Limit contact to five minutes. Oxalic acid solutions or acetic acid (vinegar) may be used for the same purpose. Flush with water. *Caution:* acid solutions are corrosive and toxic.

Flush all surfaces with copious amounts of water after use.

## WARRANTY

Misuse or abuse of any of the cleaning agents listed above will result in a voiding of warranty for the surface affected. For additional information contact Great Northern's Tech Department at 406-624-0435



## Tuf Rib Panel

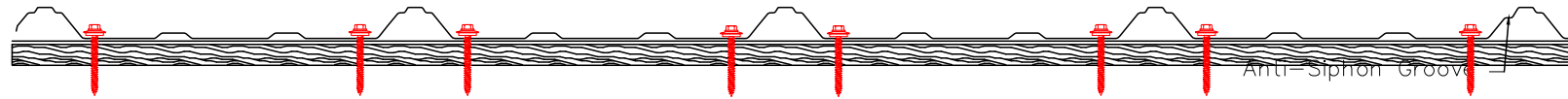

TYPICAL FASTENER PLACEMENT AT EAVE

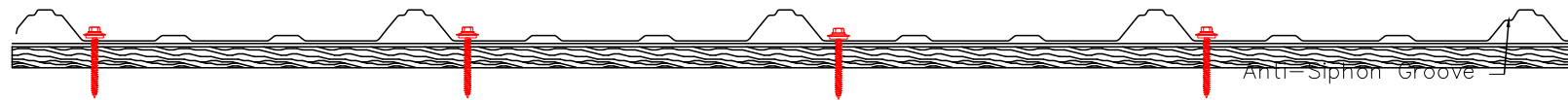

TYPICAL FASTENER PLACEMENT AT FIELD 24" O.C.  
RECOMMENDED

## Rugged Rib Panel

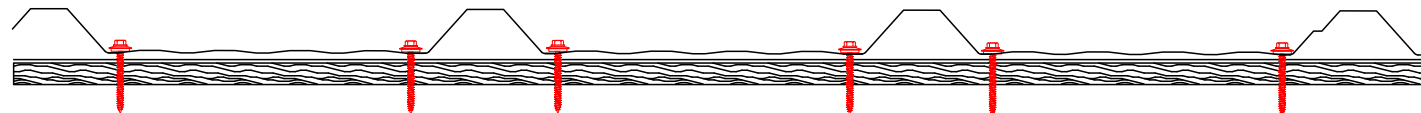

TYPICAL FASTENER PLACEMENT AT EAVE

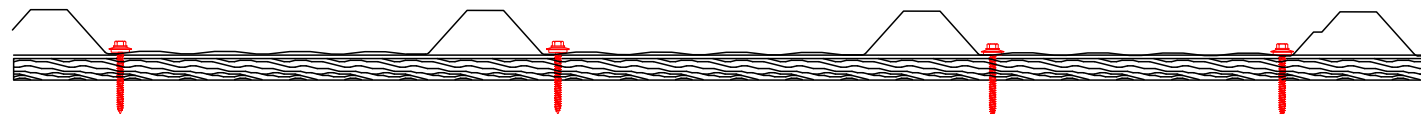

TYPICAL FASTENER PLACEMENT AT FIELD 24" O.C.  
RECOMMENDED



PBR Panel

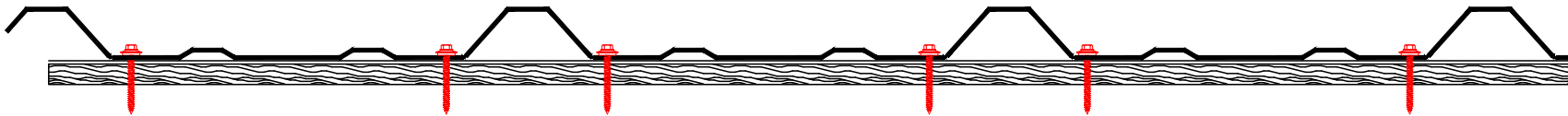

TYPICAL FASTENER PLACEMENT AT EAVE

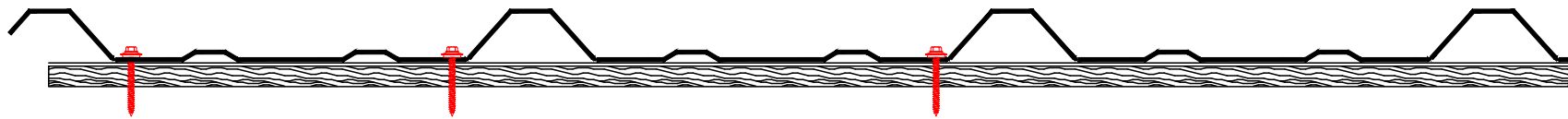

TYPICAL FASTENER PLACEMENT AT FIELD 24" O.C.  
RECOMMENDED

Lo Pro Panel

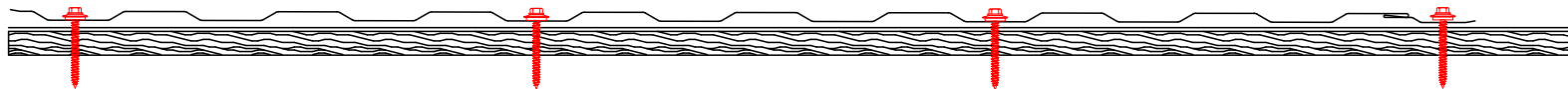

TYPICAL FASTENER PLACEMENT AT FIELD 24" O.C.  
RECOMMENDED





## 7/8" Corrugated Panel Roofing

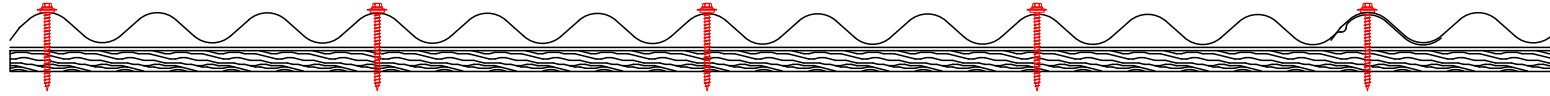

TYPICAL FASTENER PLACEMENT AT EAVE & FIELD 24"O.C.  
RECOMMENDED

## 7/8" Corrugated Panel Siding

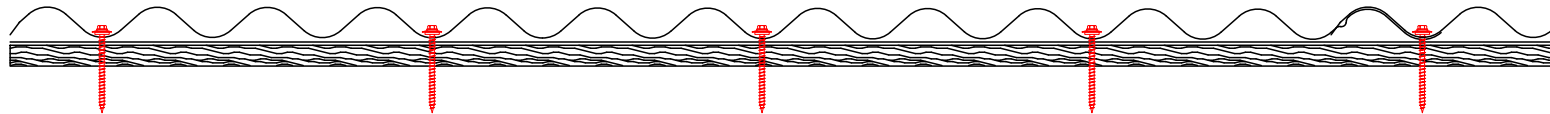

TYPICAL FASTENER PLACEMENT AT FIELD 24"O.C.  
RECOMMENDED



## 1/2" Corrugated Panel Roofing



TYPICAL FASTENER PLACEMENT AT EAVE & FIELD 24" O.C.C  
RECOMMENDED

## 1/2" Corrugated Panel Siding



TYPICAL FASTENER PLACEMENT AT FIELD 24" O.C.  
RECOMMENDED



## 1/4" Corrugated Panel Siding (Only)

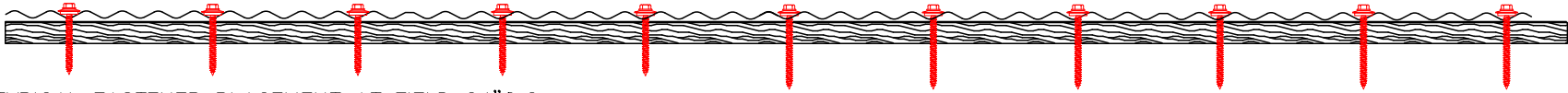

TYPICAL FASTENER PLACEMENT AT FIELD 24" O.C.  
RECOMMENDED

## 7.2 Box Rib Panel

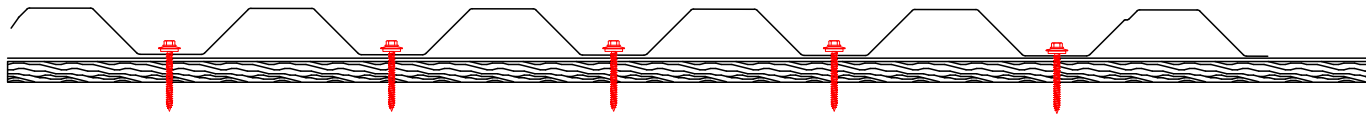

TYPICAL FASTENER PLACEMENT AT FIELD 24" O.C.  
RECOMMENDED



# GNMC

- PLYWOOD SUBSTRATE
- FASTENER @ 12" O.C.
- FOAM CLOSURE W/ ADHESIVE
- FASTENER PER PANEL REQ
- APPROVED UNDERLAYMENT
- EAVE TRIM
- FASCIA TRIM (IF REQ'D)
- TRIM BOARDS, BY OTHERS

**NOTE:**  
 MIN. 4" LAP ON ALL FLASHING.  
 APPROVED SEALANT IN ALL  
 FLASHING LAPS.

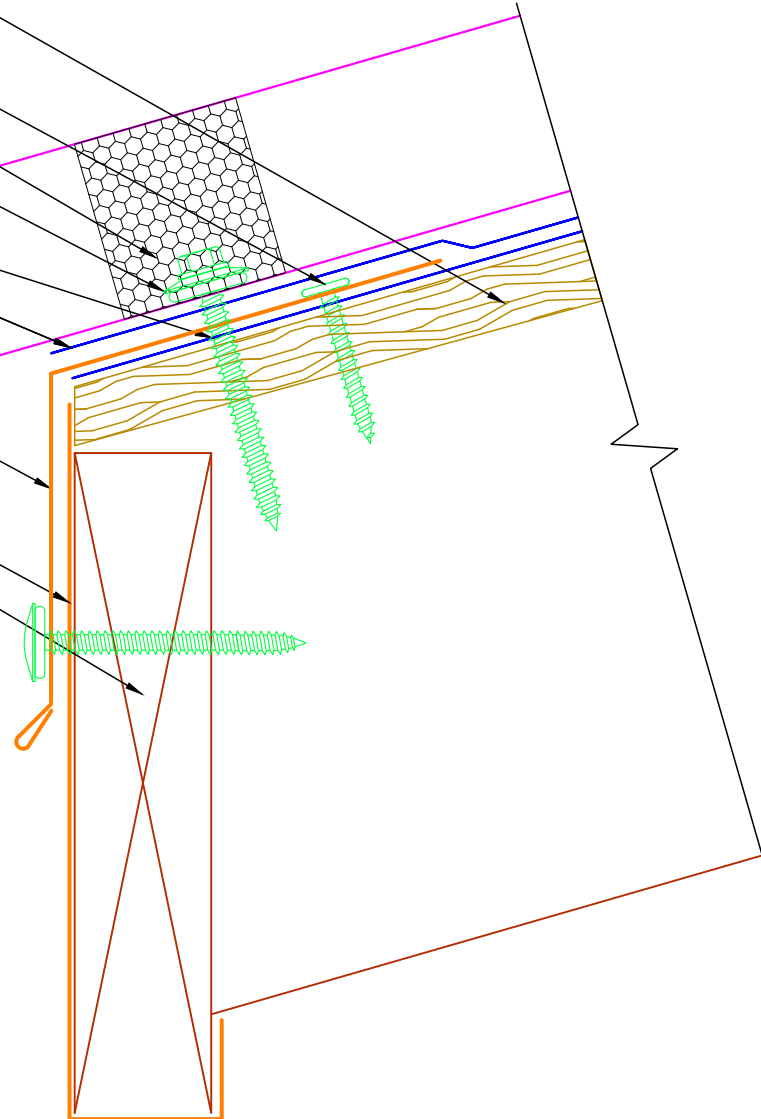

EXPOSED FASTENER PLYWOOD DETAILS

## E1 – 4" Eave Detail



# GNMC

PLYWOOD SUBSTRATE

FASTENER @ 12" O.C.

FOAM CLOSURE W/ ADHESIVE

APPROVED UNDERLAYMENT

EAVE TRIM

FASCIA TRIM (IF REQ'D)

TRIM BOARDS, BY OTHERS

NOTE:  
MIN. 4" LAP ON ALL FLASHING.  
APPROVED SEALANT IN ALL FLASHING LAPS.

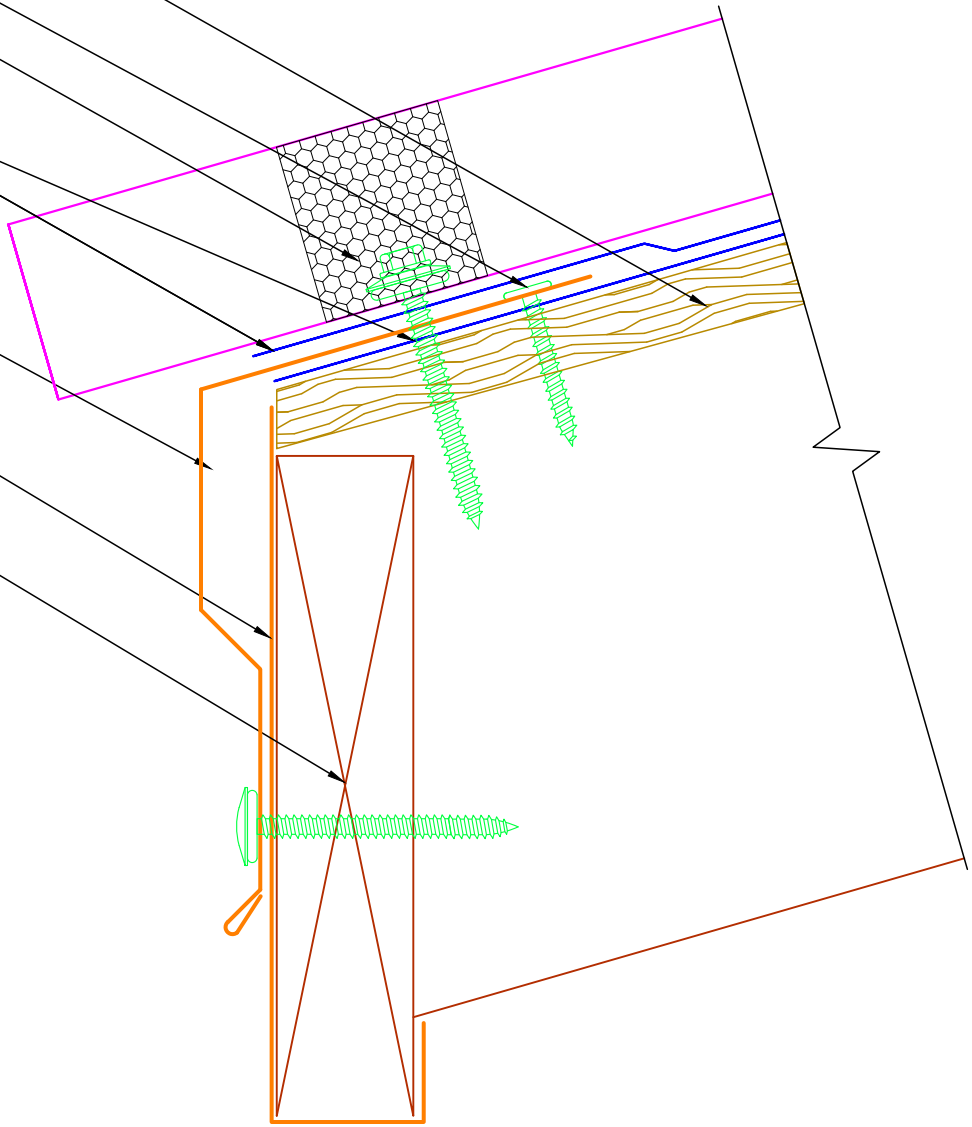

EXPOSED FASTENER PLYWOOD DETAILS

**E2 – 6" Eave Detail**



# GNMC

- PLYWOOD SUBSTRATE
- FASTENER @ 12" O.C.
- FOAM CLOSURE W/ ADHESIVE
- FASTENER PER PANEL REQ
- APPROVED UNDERLAYMENT
- EAVE TRIM
- FASCIA TRIM (IF REQ'D)
- TRIM BOARDS, BY OTHERS

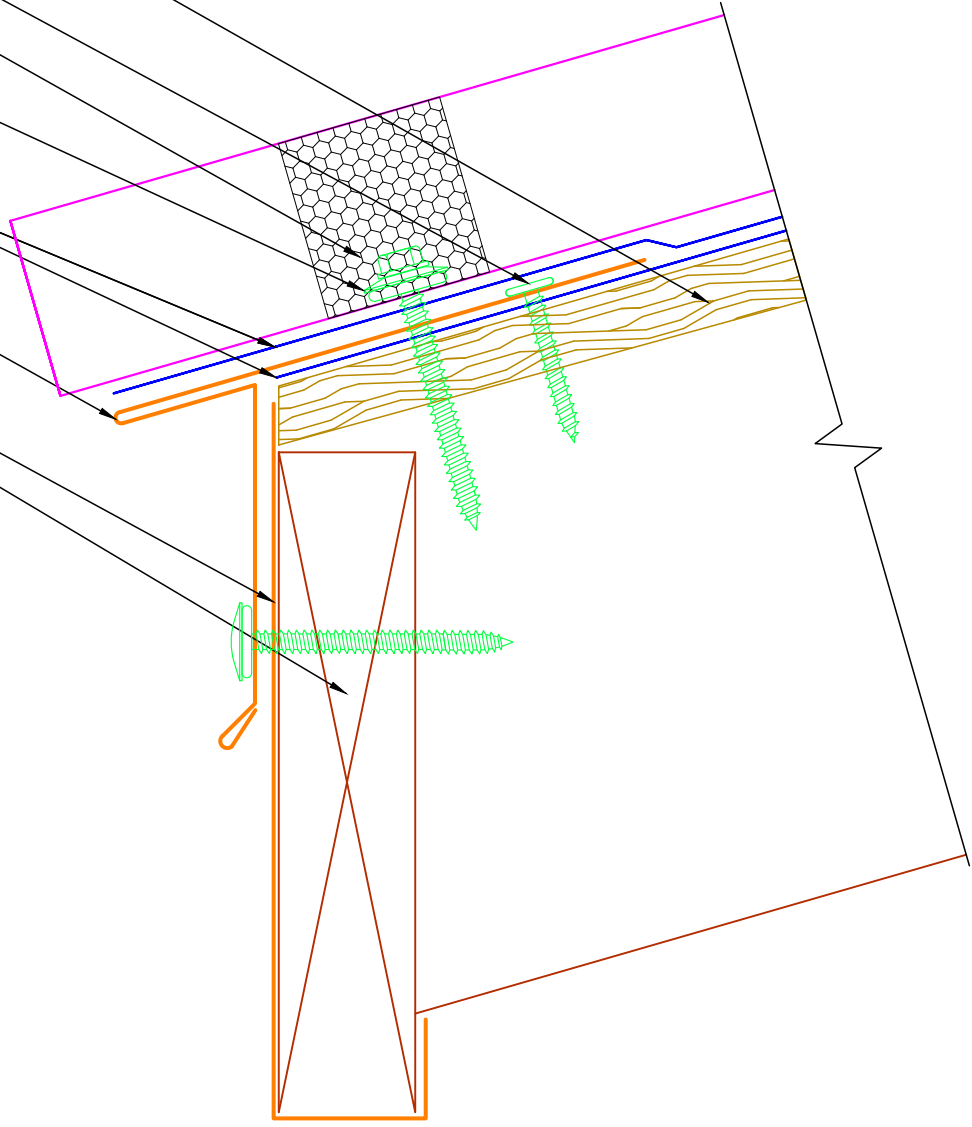

**NOTE:**  
 MIN. 4" LAP ON ALL FLASHING.  
 APPROVED SEALANT IN ALL  
 FLASHING LAPS.

**EXPOSED FASTENER PLYWOOD DETAILS**

**SD1 – Style D Eave Detail**



# GNMC

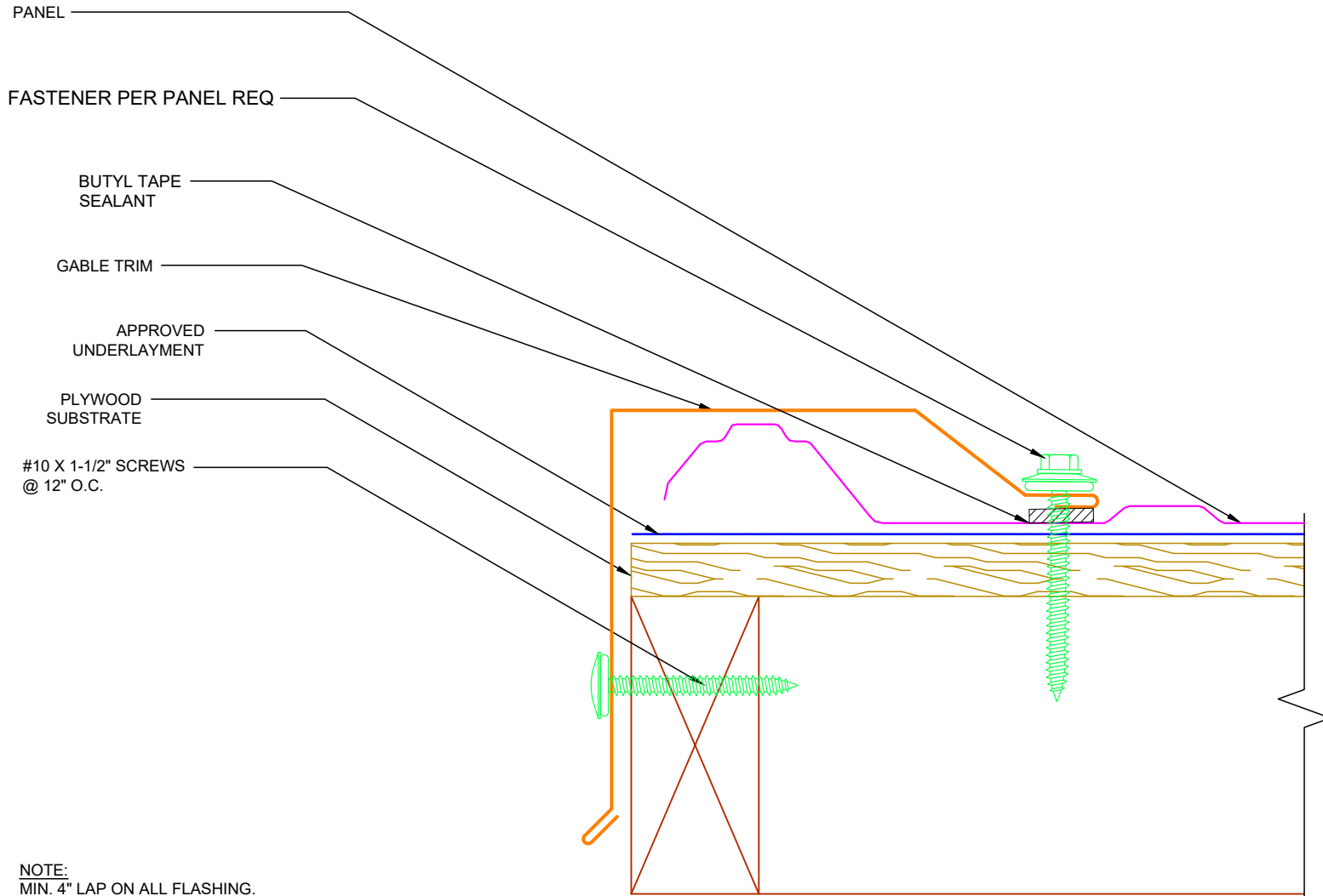

**NOTE:**  
MIN. 4" LAP ON ALL FLASHING.  
APPROVED SEALANT IN ALL  
FLASHING LAPS.

EXPOSED FASTENER PLYWOOD DETAILS

**G1 – 4" Gable Detail**

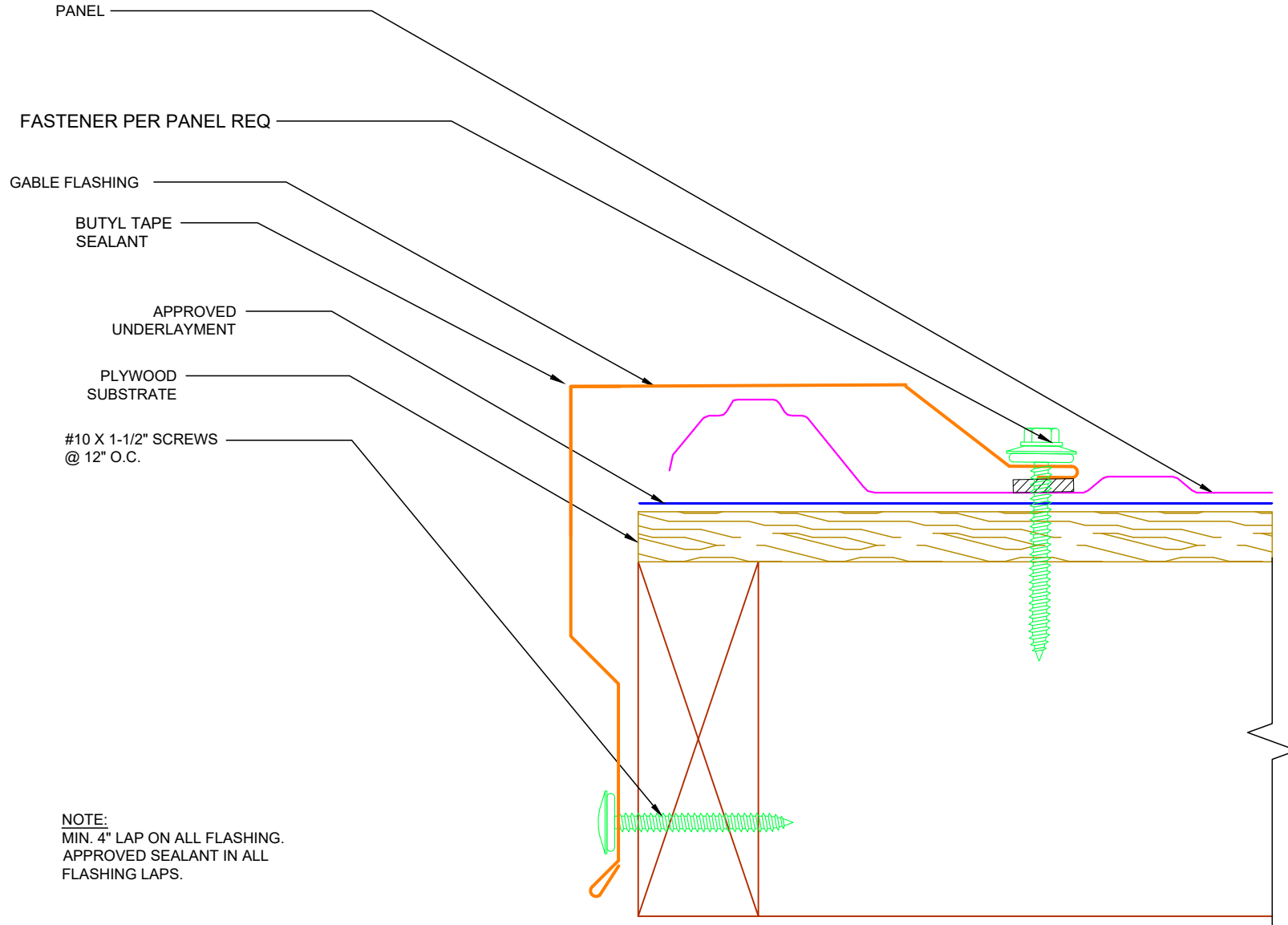

EXPOSED FASTENER PLYWOOD DETAILS



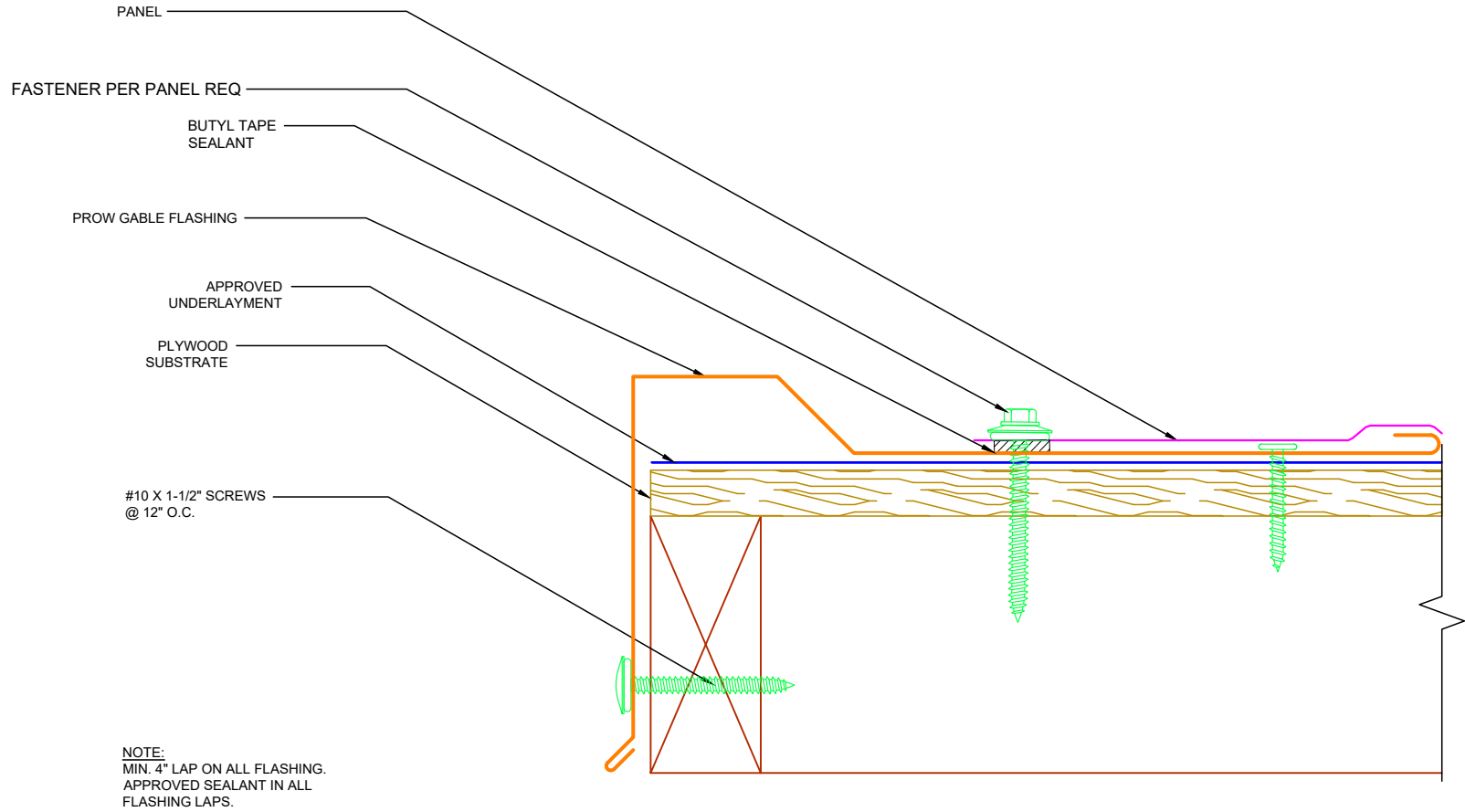

## EXPOSED FASTENER PLYWOOD DETAILS

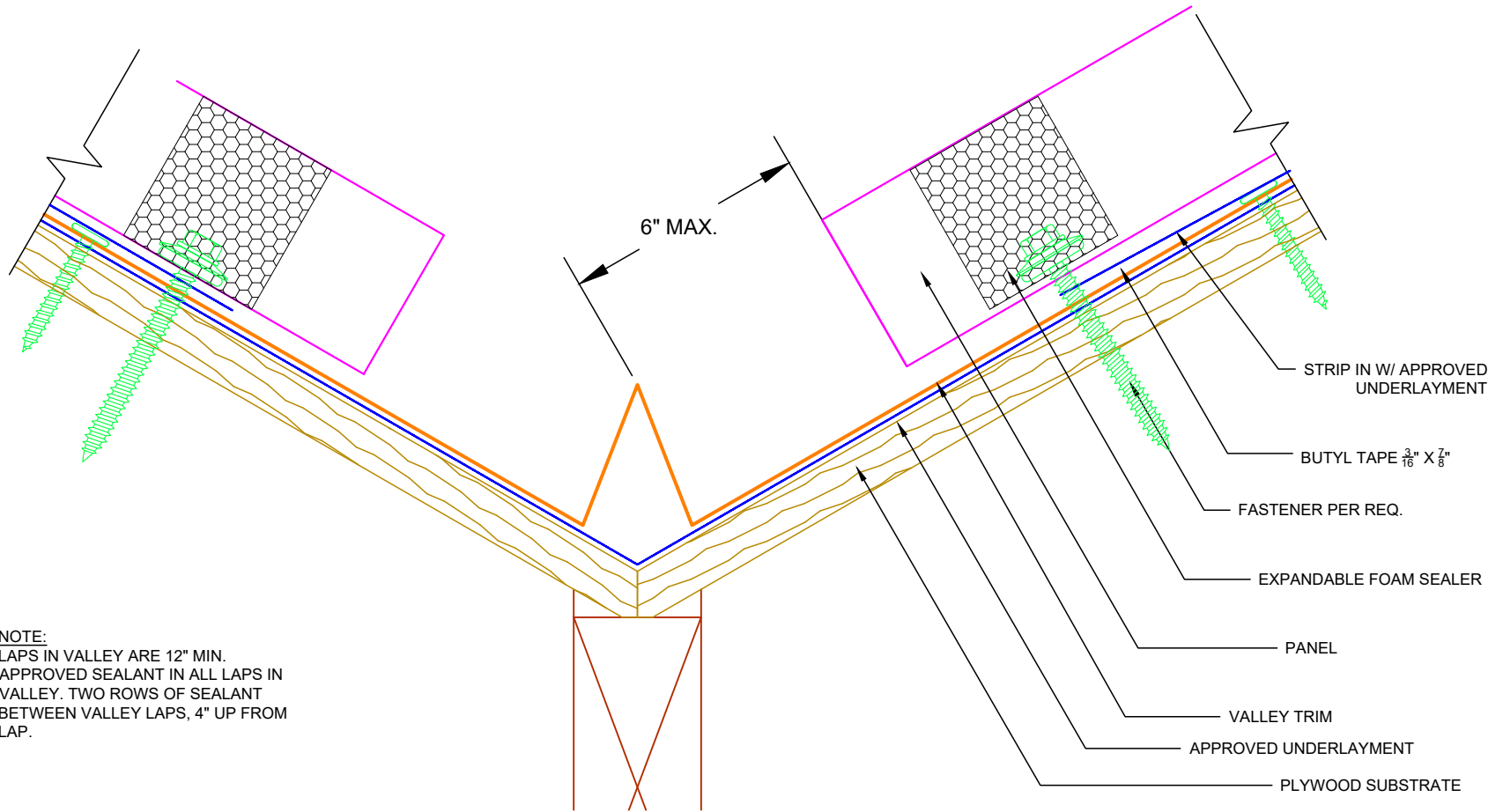

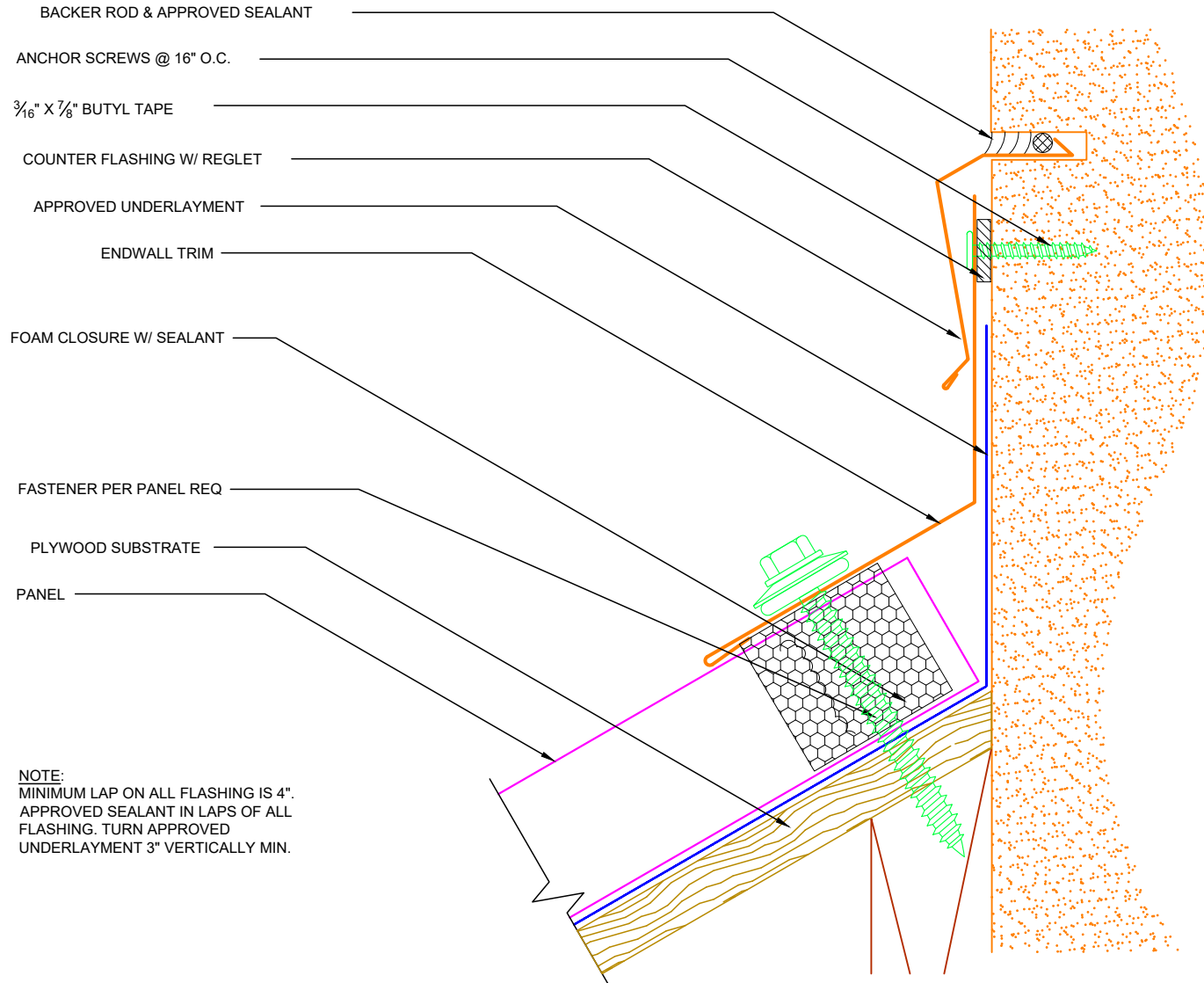

## EXPOSED FASTENER PLYWOOD DETAILS

**EW1 – Endwall Detail**

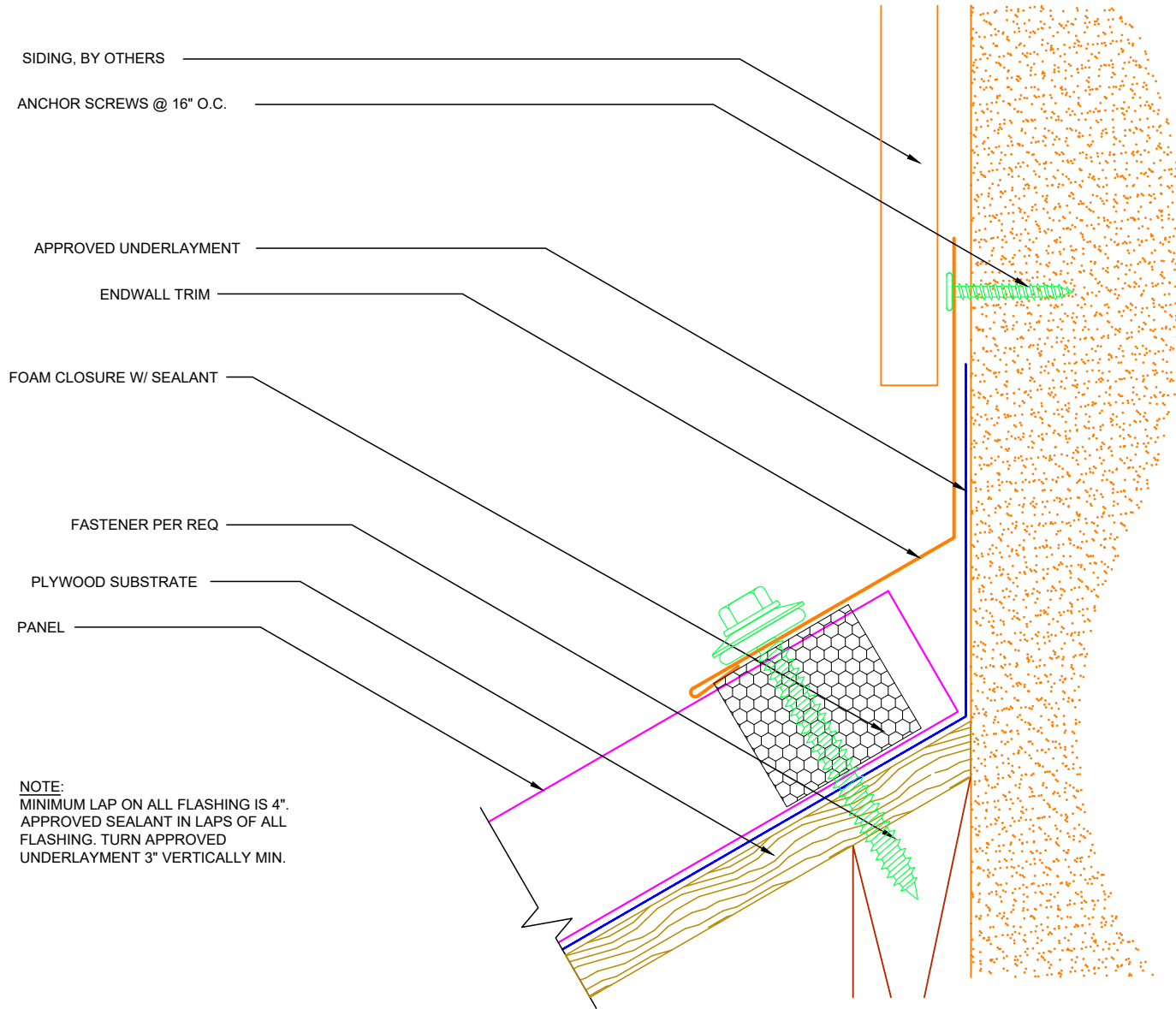

## EXPOSED FASTENER PLYWOOD DETAILS

**EW2 – Endwall Detail**

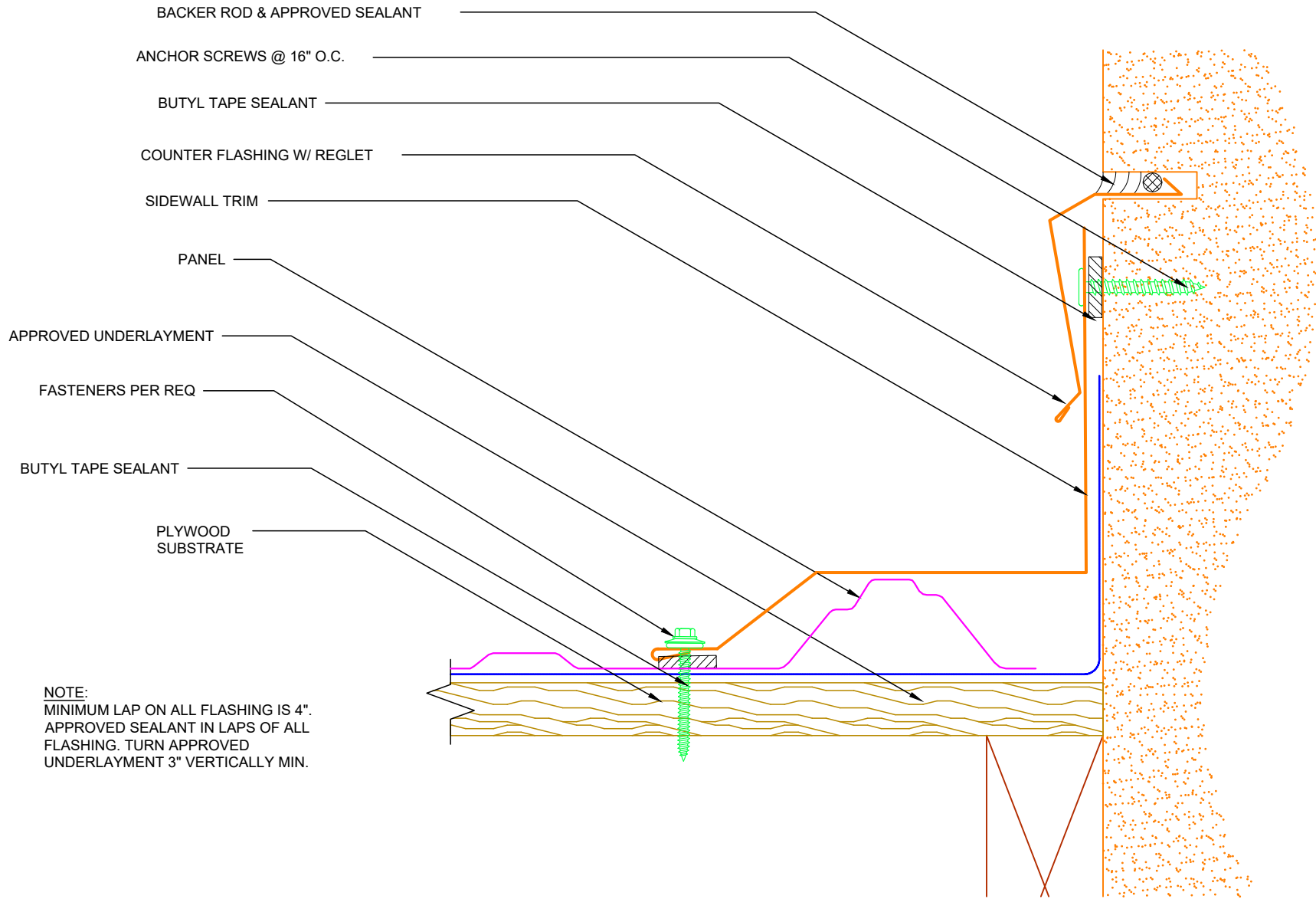

## EXPOSED FASTENER PLYWOOD DETAILS

**SW1 – Sidewall Detail**



# GNMC

SIDING BY OTHERS

ANCHOR SCREWS @ 16" O.C.

$\frac{3}{16}$ " x  $\frac{7}{8}$ " BUTYL TAPE

SIDEWALL TRIM

APPROVED UNDERLAYMENT

FASTENERS PER REQ

BUTYL TAPE SEALANT

PLYWOOD SUBSTRATE

NOTE:  
MINIMUM LAP ON ALL FLASHING IS 4".  
APPROVED SEALANT IN LAPS OF ALL  
FLASHING. TURN APPROVED  
UNDERLAYMENT 3" VERTICALLY MIN.

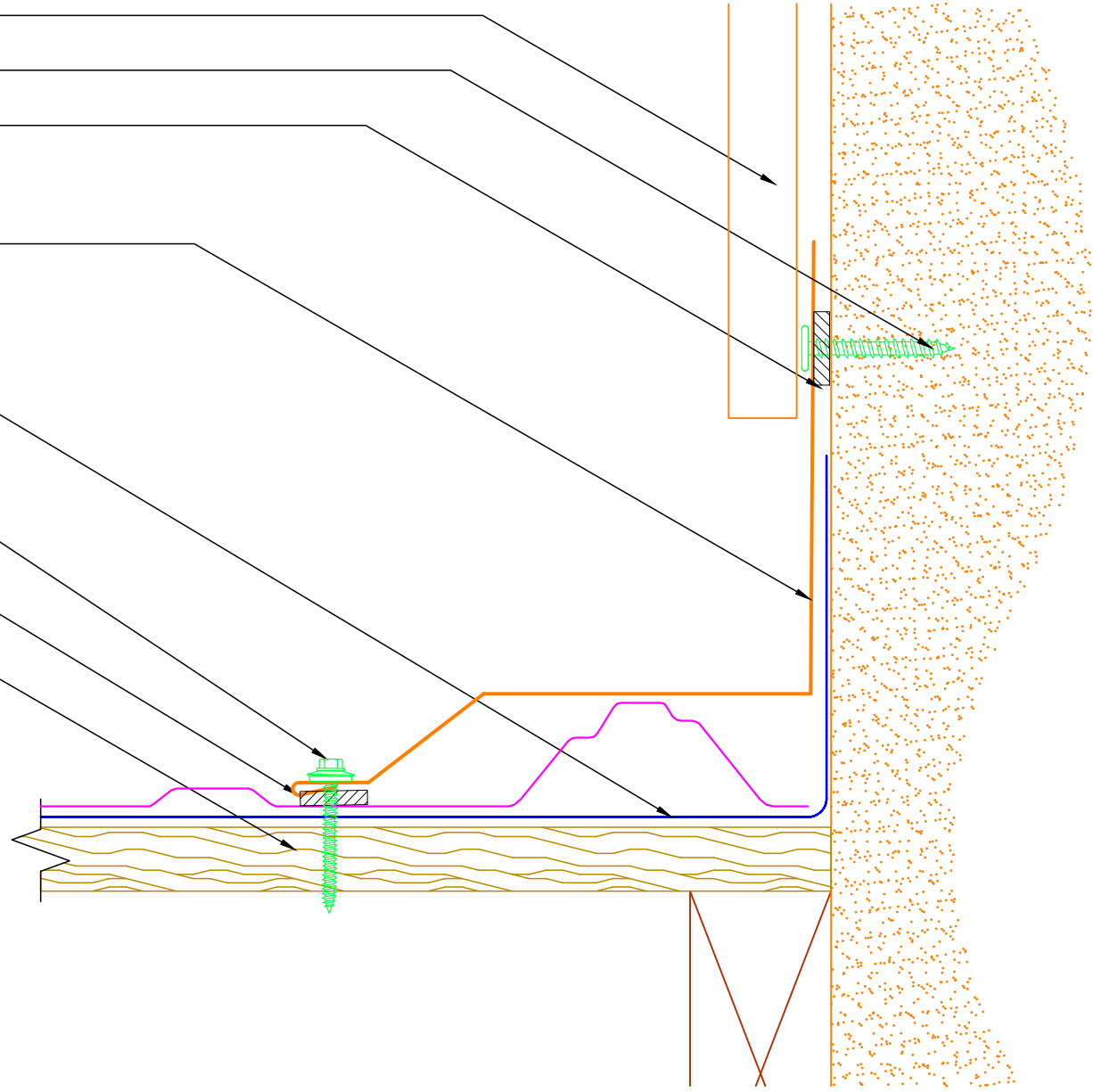

EXPOSED FASTENER PLYWOOD DETAILS

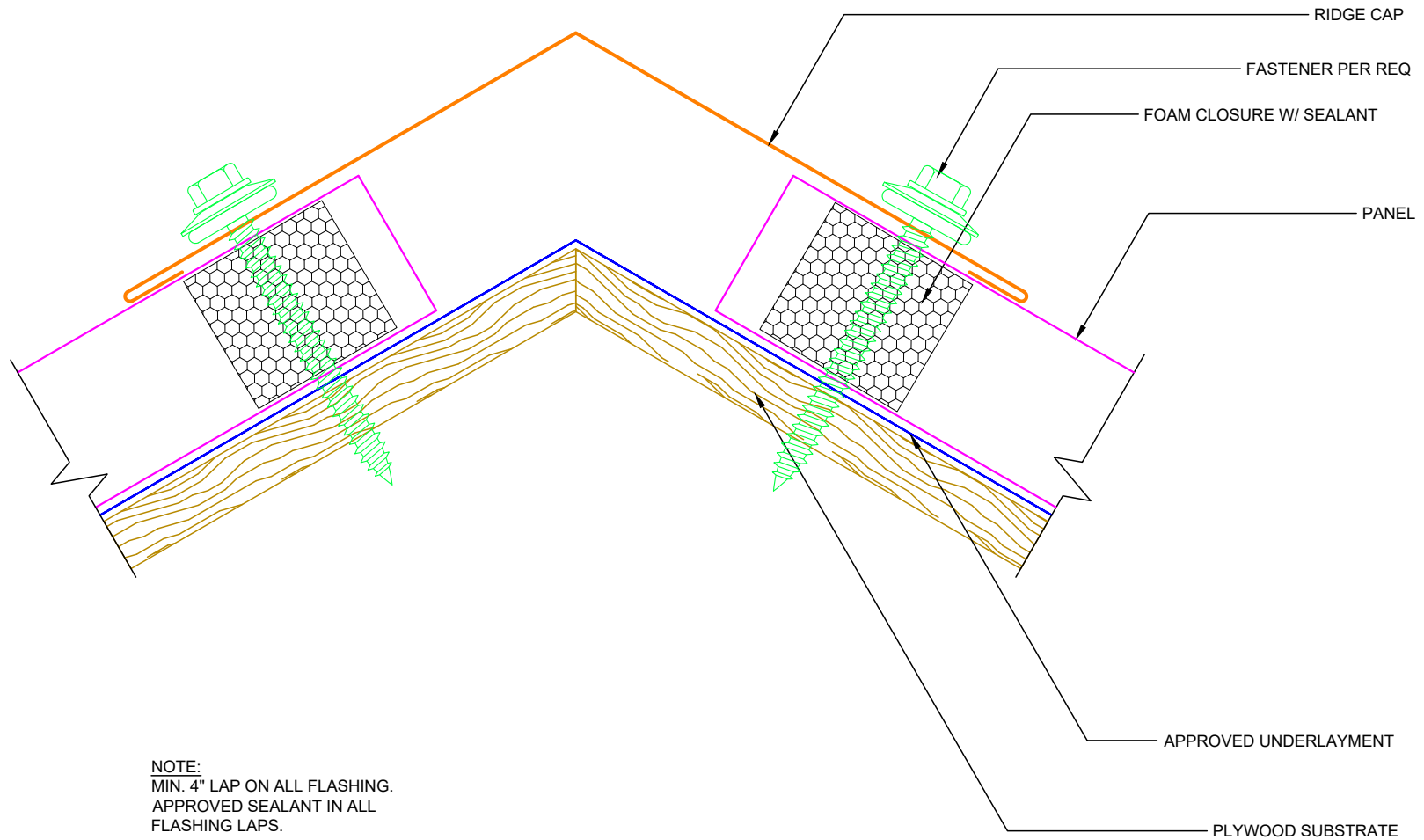

**EXPOSED FASTENER PLYWOOD DETAILS**

**HR1 – Hip Ridge Detail**

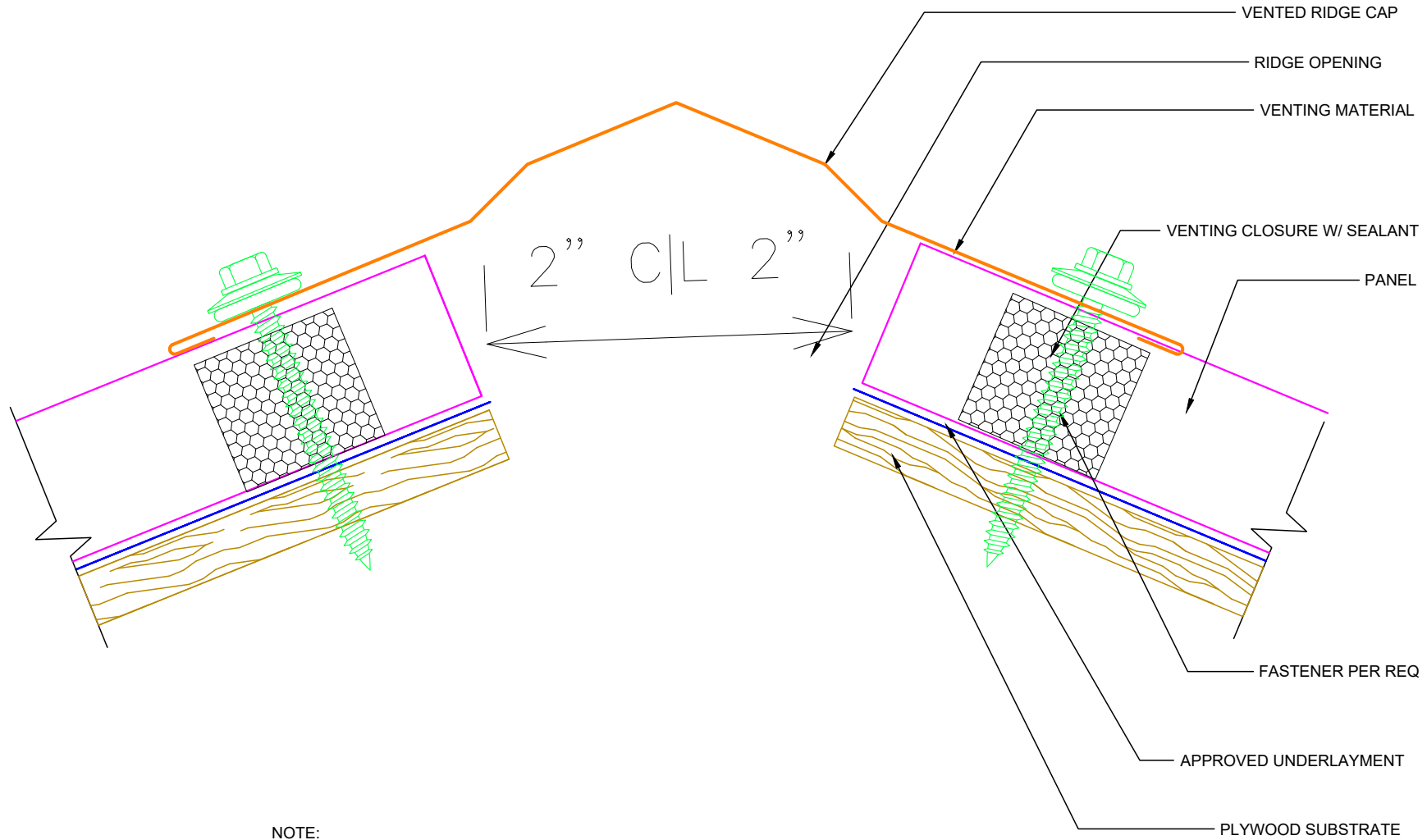

NOTE:  
 MIN. 4" LAP ON ALL FLASHING.  
 APPROVED SEALANT IN ALL  
 FLASHING LAPS.



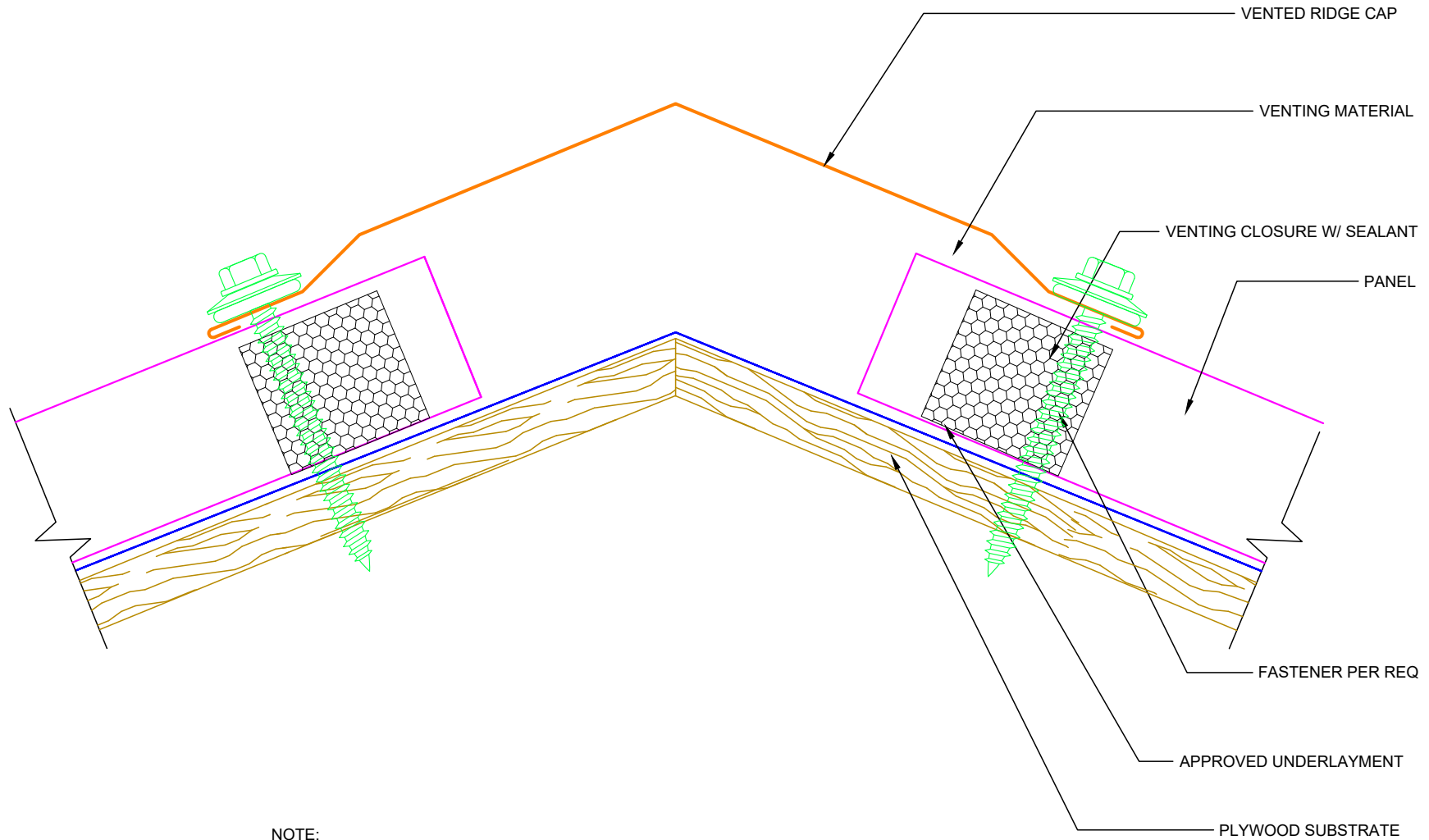

**NOTE:**  
 MIN. 4" LAP ON ALL FLASHING.  
 APPROVED SEALANT IN ALL  
 FLASHING LAPS.

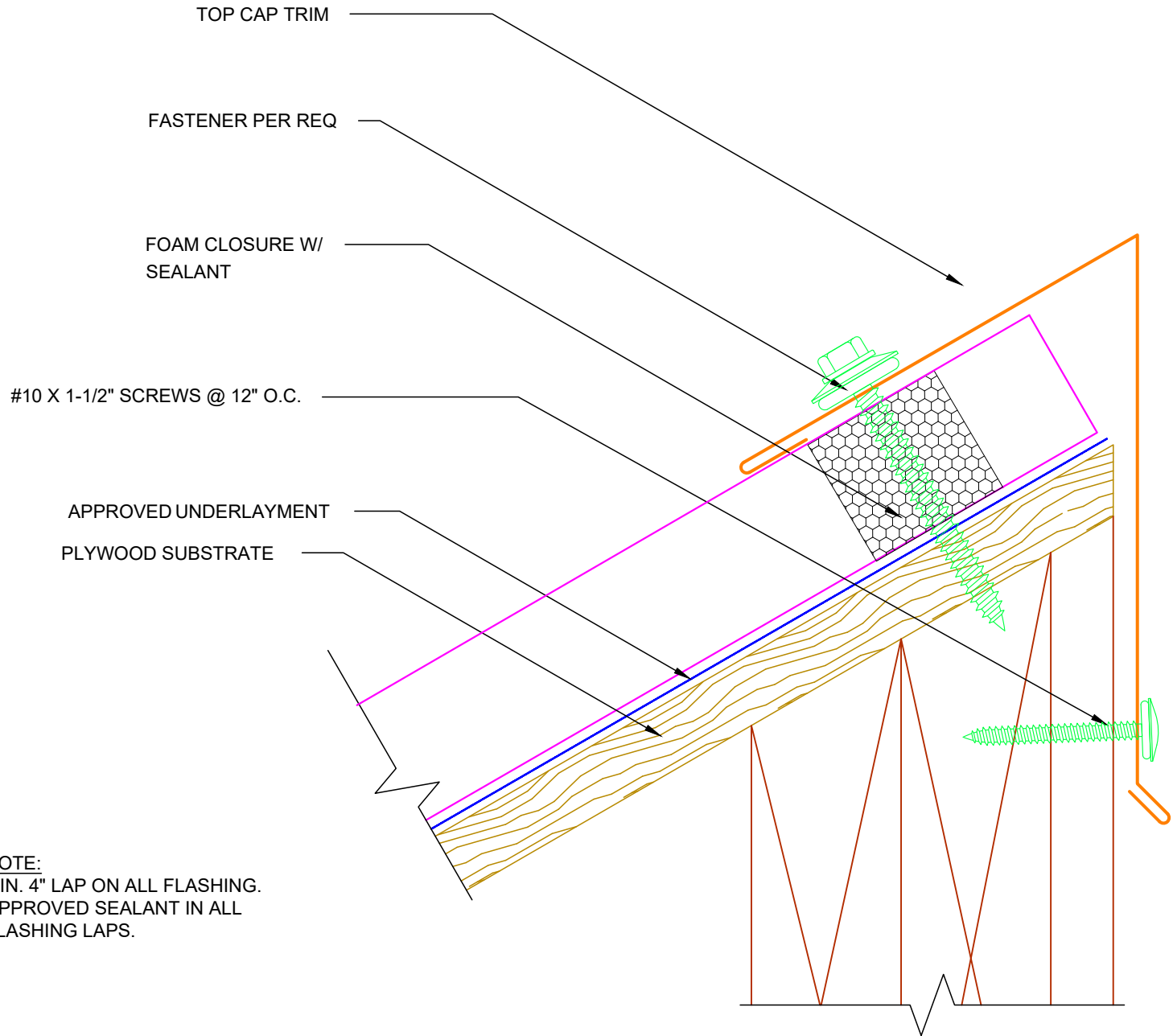

EXPOSED FASTENER PLYWOOD DETAILS

**TC1 – 4" Top Cap Detail**

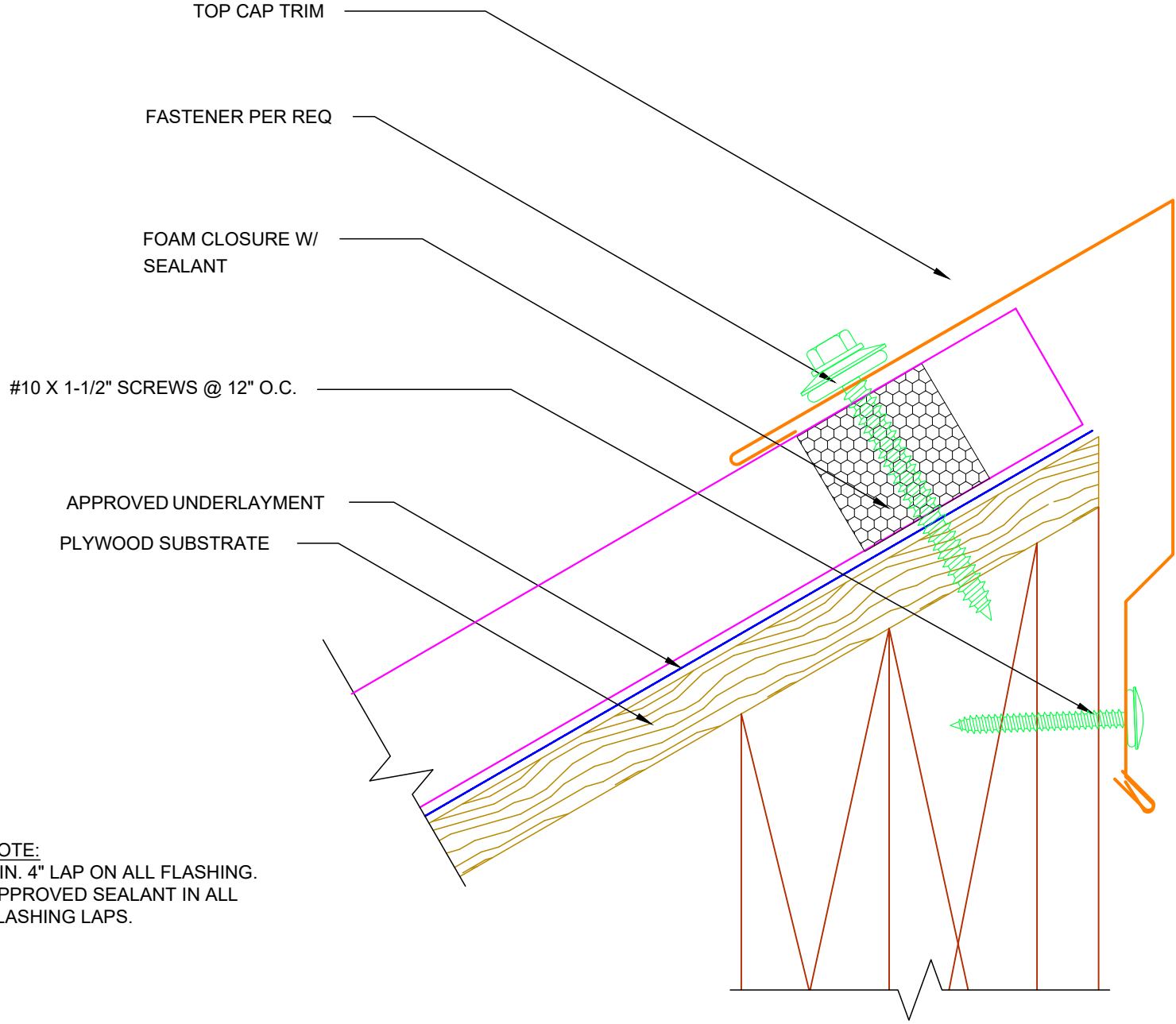

EXPOSED FASTENER PLYWOOD DETAILS

**TC2 – 6" Top Cap Detail**

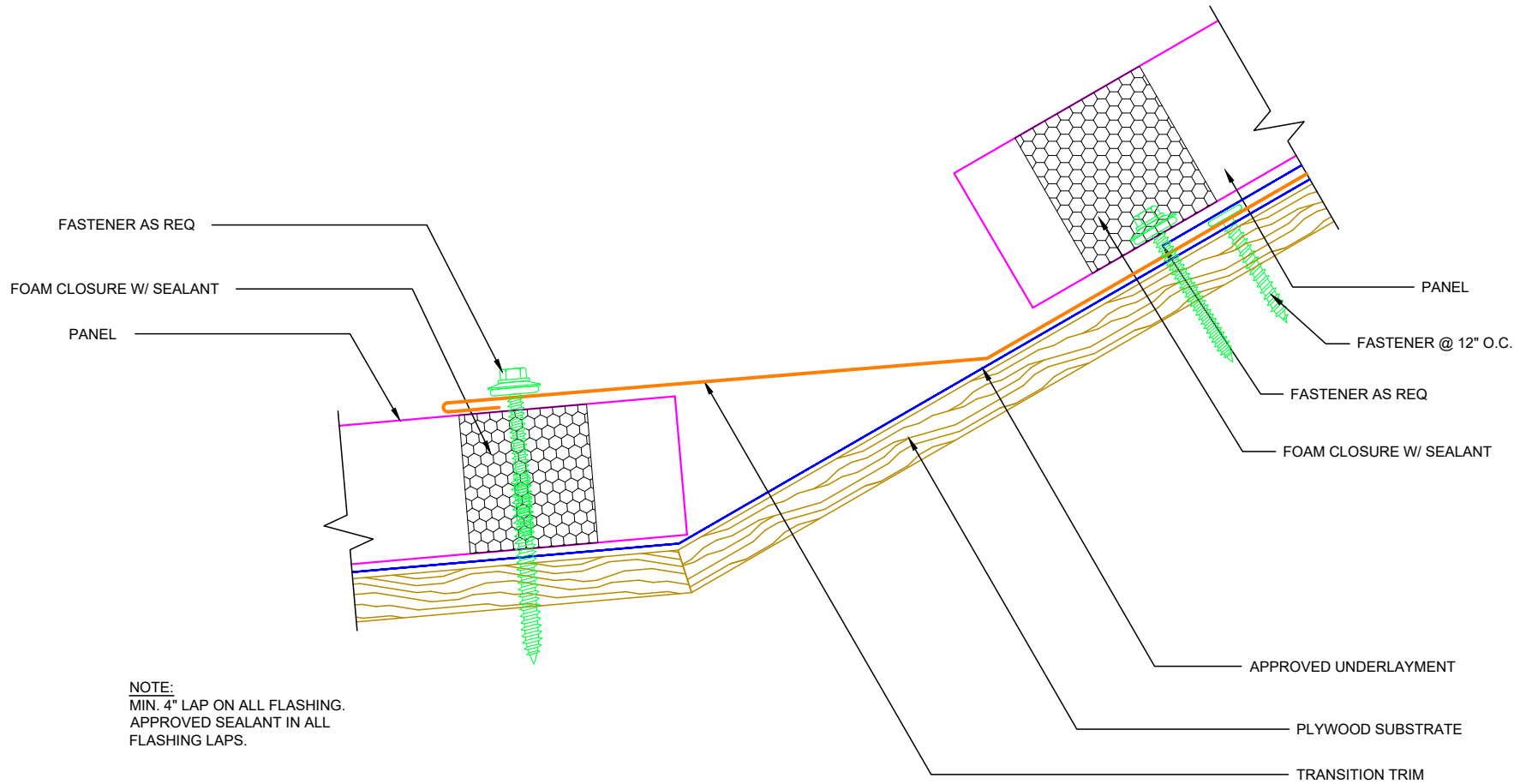

**EXPOSED FASTENER PLYWOOD DETAILS**

**T1 – Roof Transition Detail**

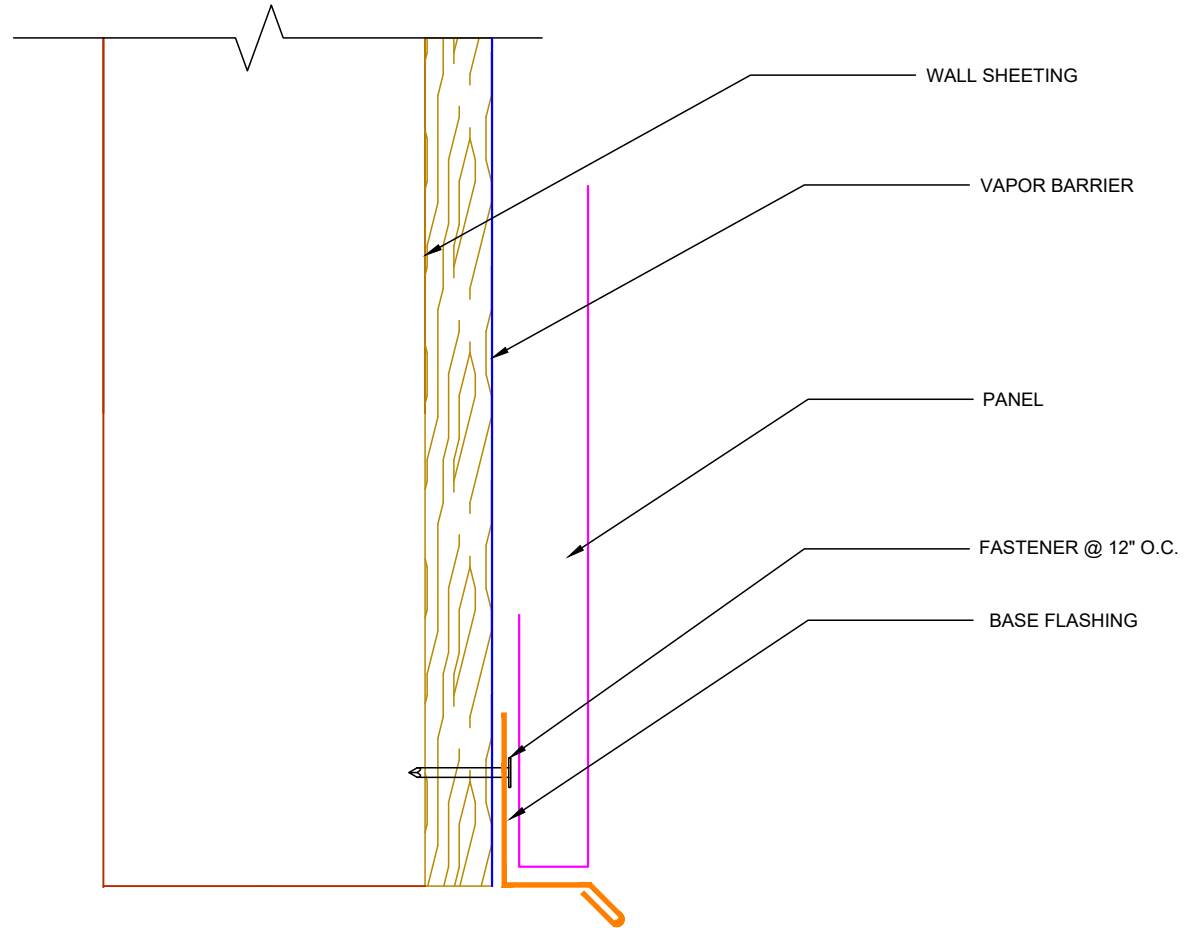

**B1 – Base Flashing Detail**

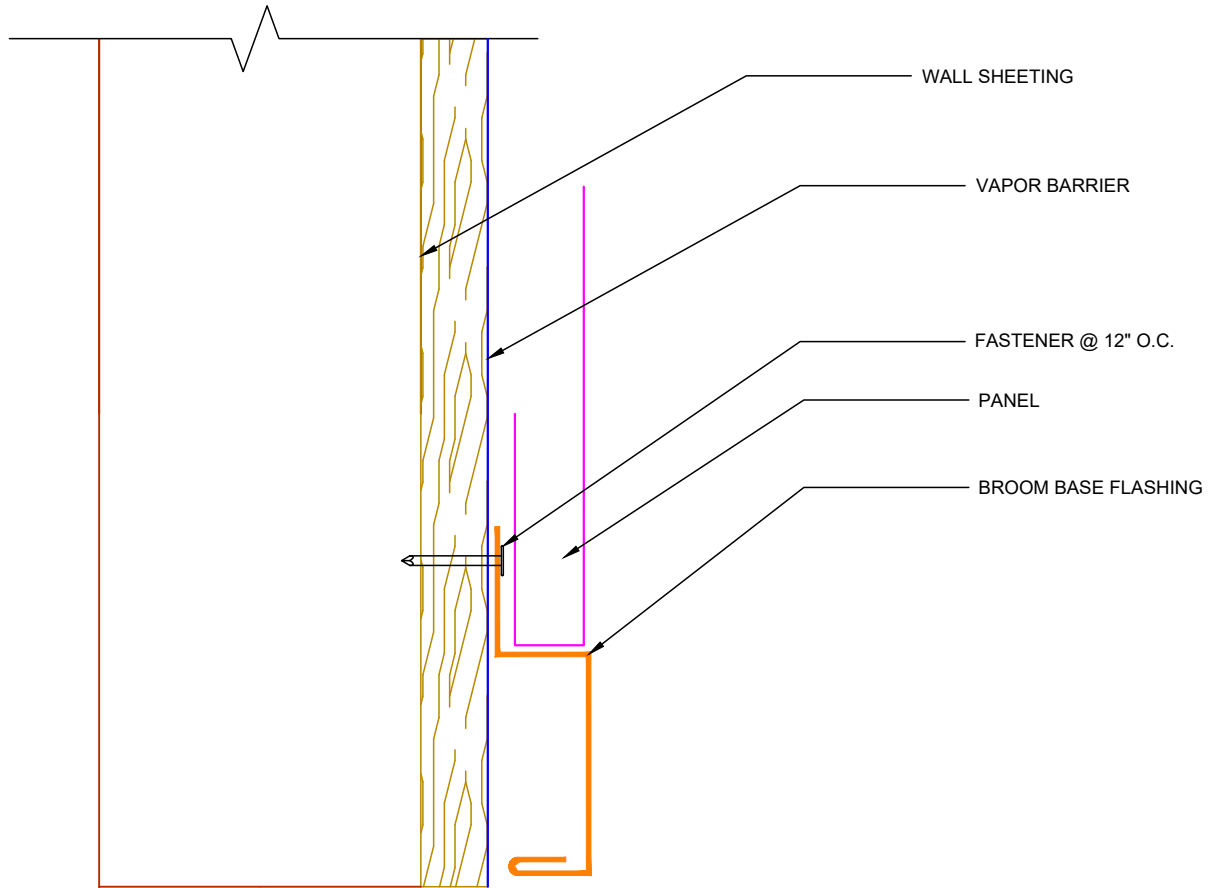

**EXPOSED FASTENER PLYWOOD DETAILS**

**BB1 – Broom Base Flashing Detail**

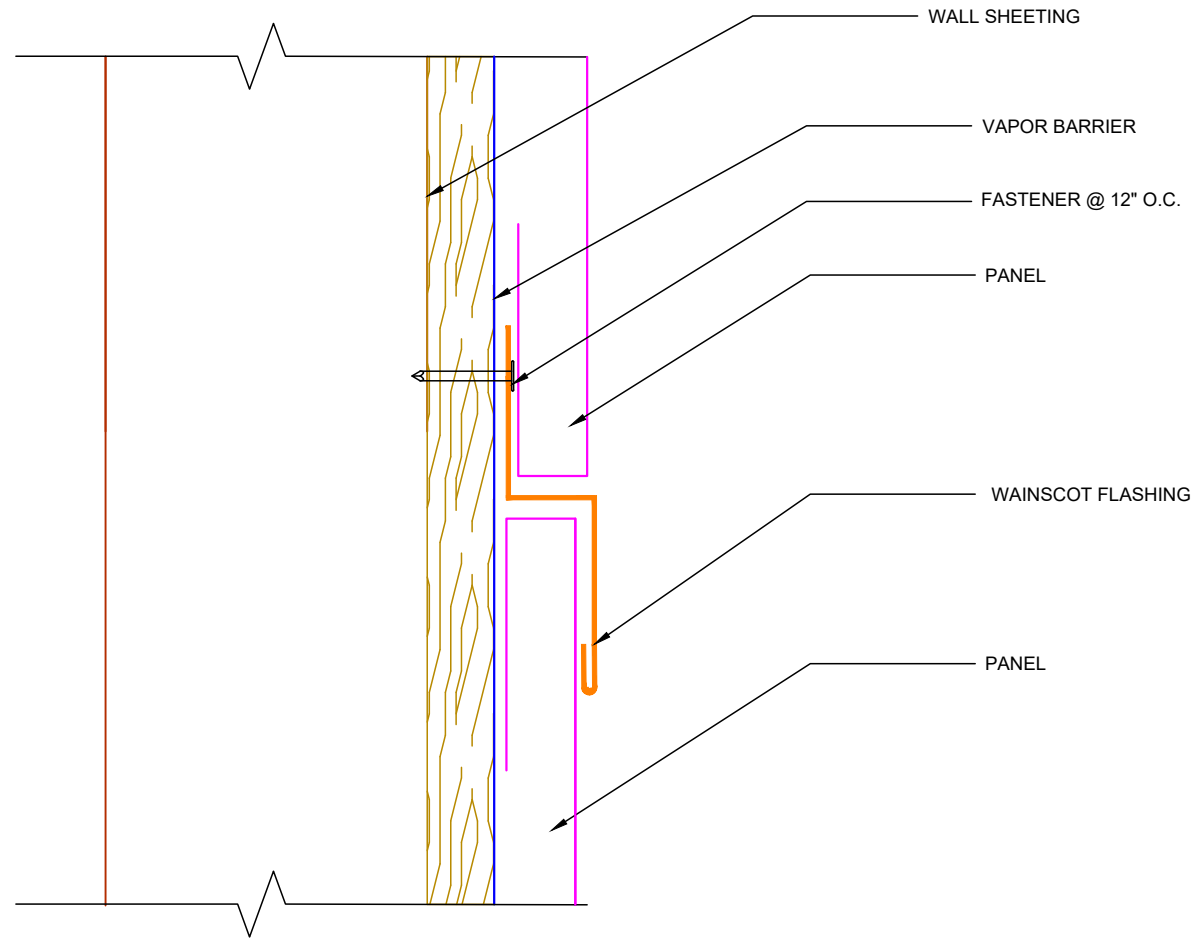

**EXPOSED FASTENER PLYWOOD DETAILS**

**WC1 – Wainscot Flashing Detail**

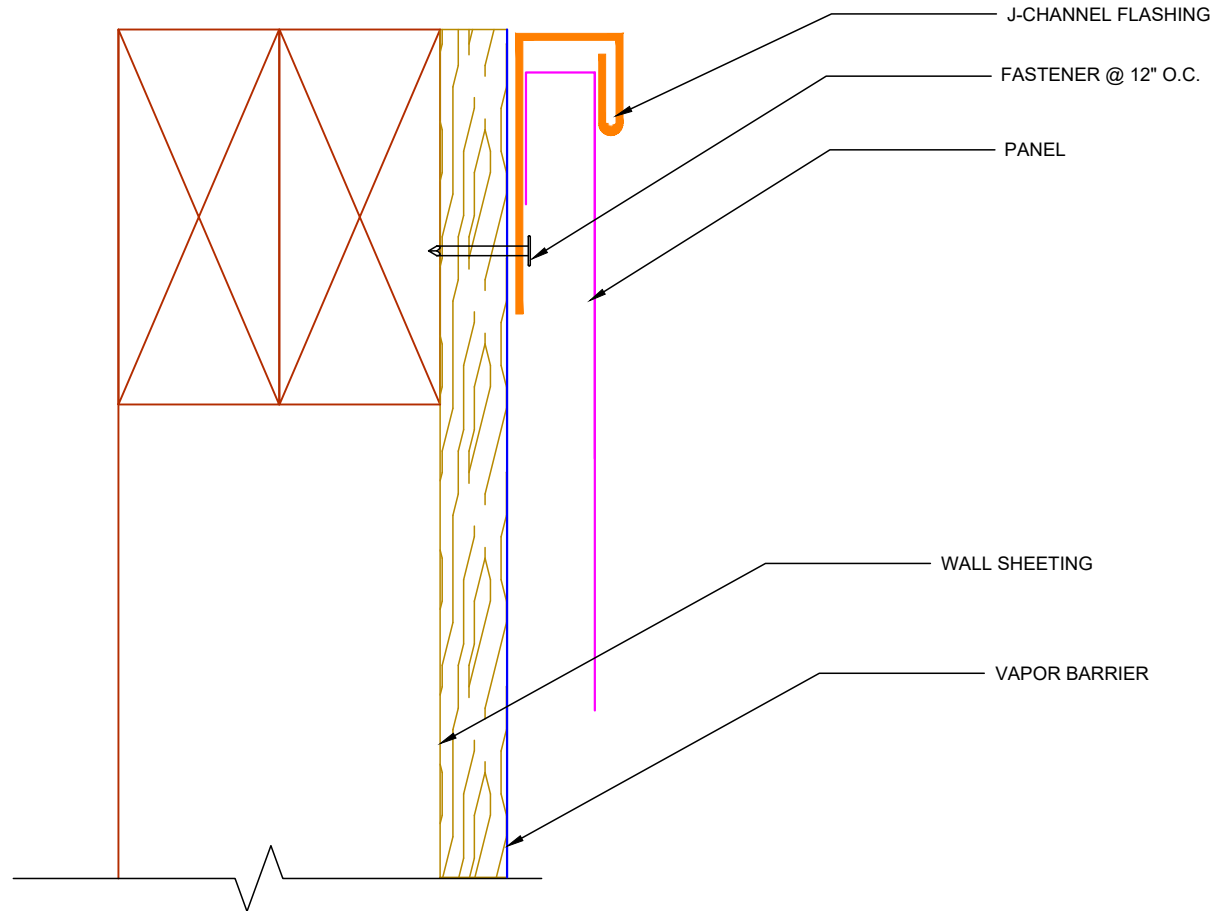

EXPOSED FASTENER PLYWOOD DETAILS



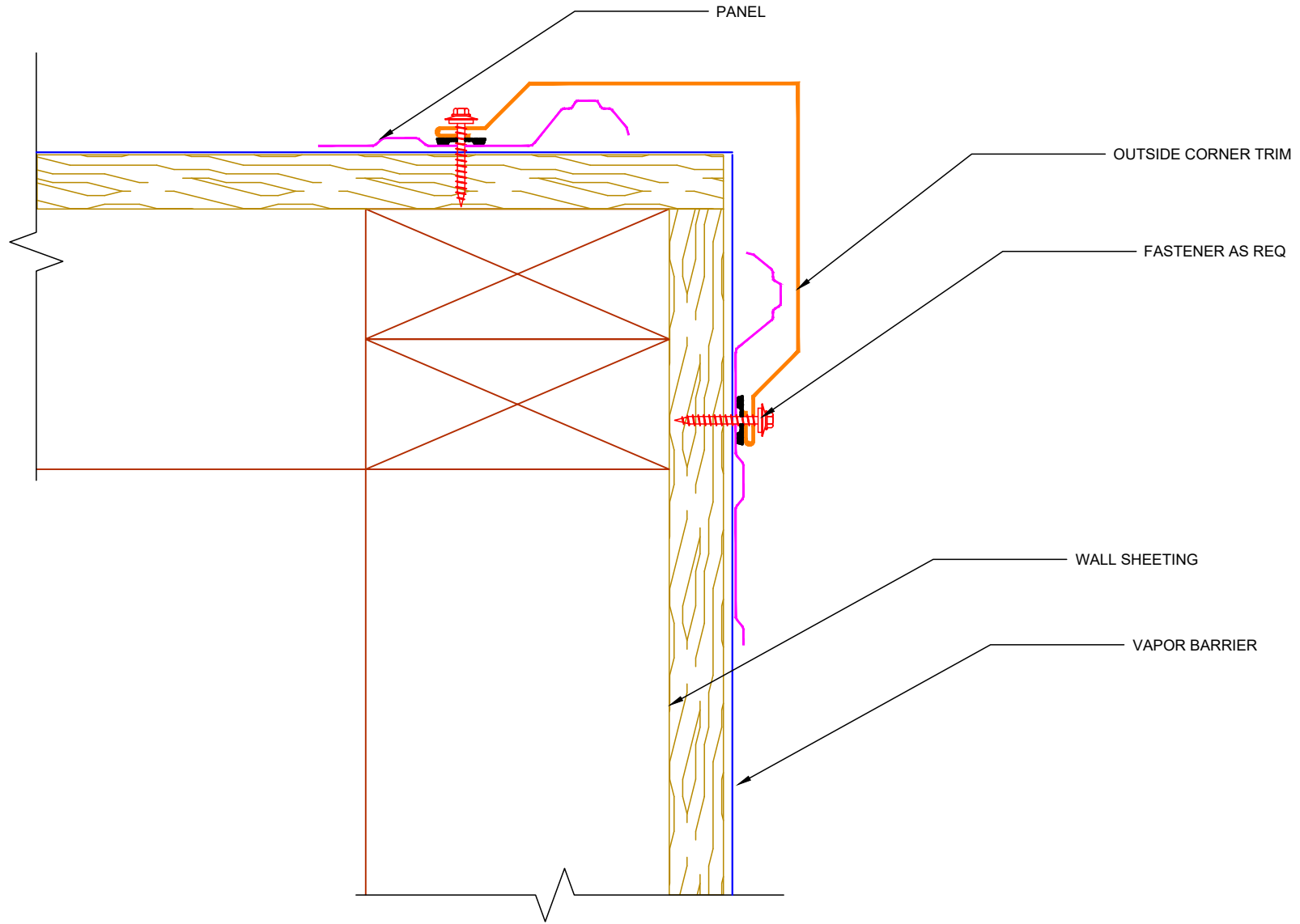

EXPOSED FASTENER PLYWOOD DETAILS

OSC – Outside Corner Detail

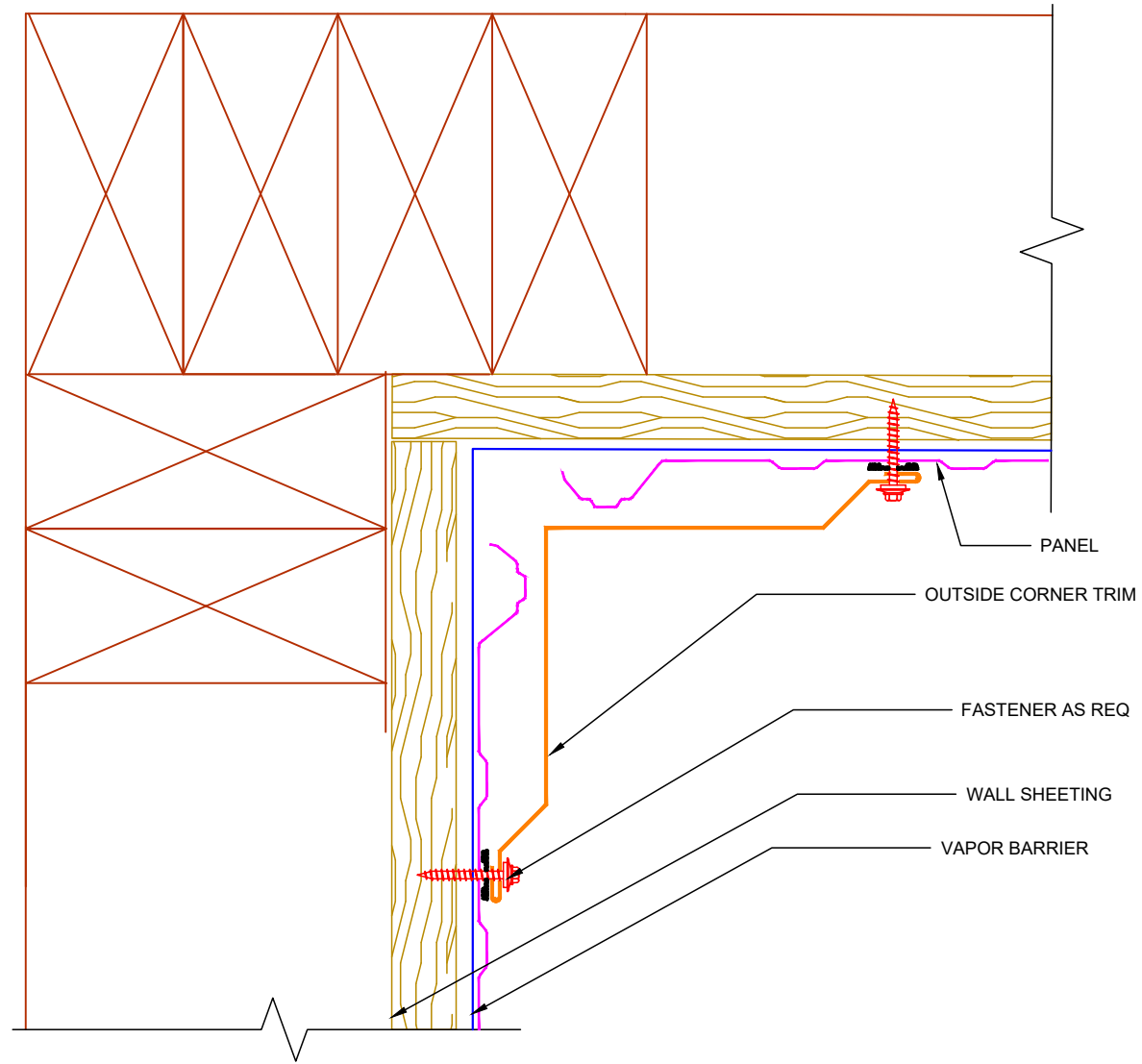

**EXPOSED FASTENER PLYWOOD DETAILS**

**ISC – Inside Corner Detail**

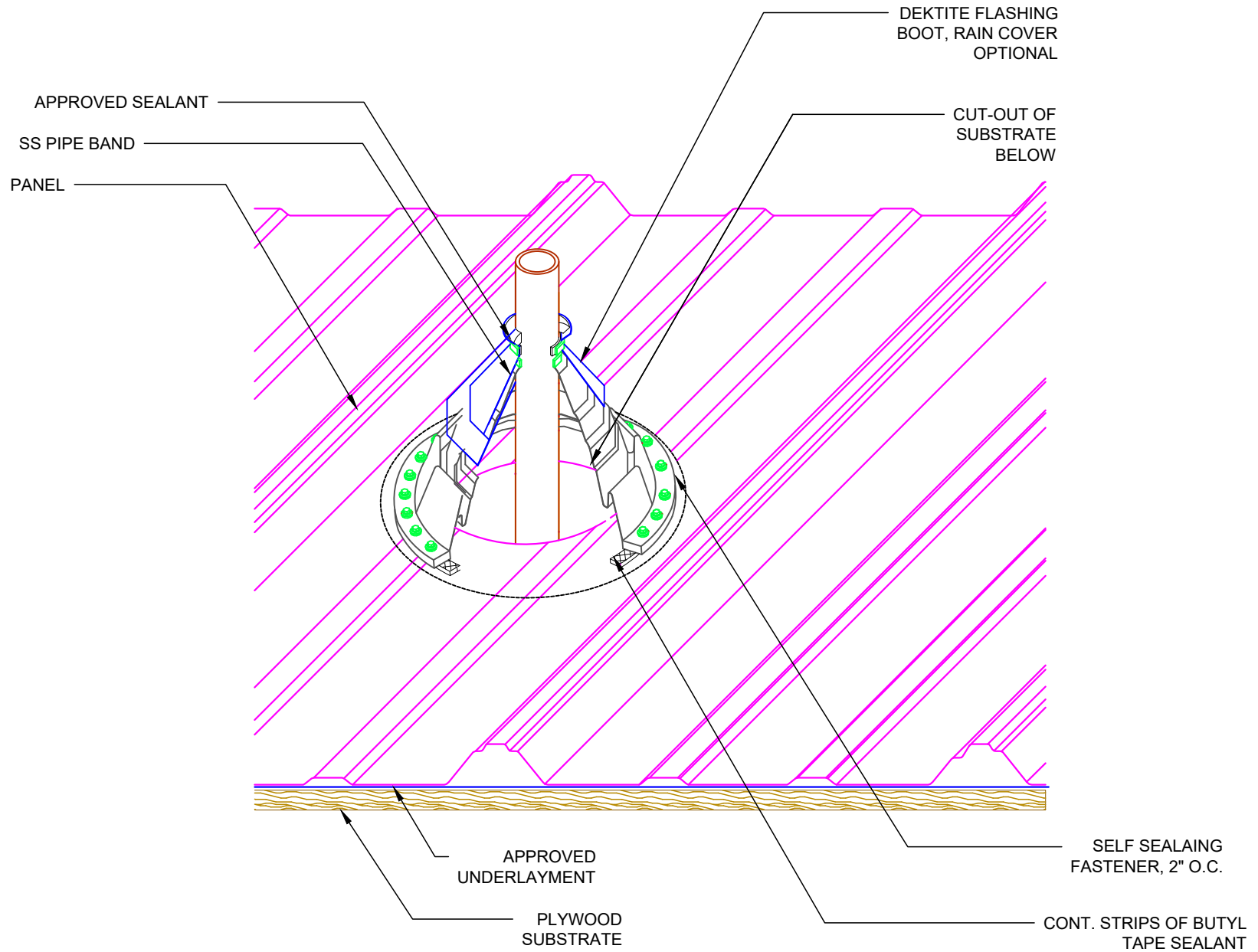

**EXPOSED FASTENER PLYWOOD DETAILS**

**PB1 - Pipe Boot**